







<b>Submittal Data: TW12HTA3D</b>		<b>12,000 BTU/H Wall Mounted Heat- Pump System</b>	
Job Name		Location	Date
Purchaser		Engineer	
Submitted To		For <input type="checkbox"/> Reference <input type="checkbox"/> Approval <input type="checkbox"/> Construction	
Unit Designation		Schedule No.	
<b>GENERAL FEATURES</b> <ul style="list-style-type: none"> <li>-World Class Performance - Ultra High Efficiency</li> <li>-Energy Saving Function</li> <li>-7 Fan Speeds / 4 Way Airflow Operation</li> <li>-Photocatalytic Filter</li> <li>-Wireless Remote with LCD Display</li> <li>-Gold Fin Condenser Coil</li> </ul> 			
System Ratings		Indoor Unit Data	
<b>Cooling</b> Rated Capacity 12000 BTU/H Capacity Range 3,100-13,000 BTU/H Power Input (Max) 1,300 W SEER 25 EER 12.8		<b>Fan Motor</b> Output Power 10 W FLA 0.1 A  <b>Airflow</b> Cooling Wet (Lo/Hi) 118/453 CFM Heating Dry (Lo/Hi) NA/430 CFM	
<b>Heating at 47° F</b> Rated Capacity 13,000 BTU/H Capacity Range 2,400-14,000 BTU/H Power Input (Max) 1,350 W HSPF 10.0 COP 3.5		<b>Sound Pressure Level</b> Cooling (Lo/Hi) 24/44 db(A) Heating (Lo/Hi) 24/44 db(A)	
<b>Heating at 17° F</b> Rated Capacity 8,000 BTU/H Capacity (Max) 11,000 BTU/H Power Input (Max) 900 W COP 2.6 Power Input (Max) 1,350 W		<b>Dimensions &amp; Weights</b> Unit Dimensions (LxHxD) 34.1 x 11.5 x 8.2-in Weight (Net/Shipping) 24/31 LBS	
Operating Range		Outdoor Unit Data	
Cooling (Max) 118°F (48 C) (Min) 5°F (-15 C) Heating (Max) 86°F (30 C) (Min) -13°F (-25 C)		<b>Compressor</b> DC Inverter Driven Rotary <b>Refrigerant Type</b> R410A <b>Fan Motor</b> Output Power 40 W FLA 0.2 A  <b>Sound Pressure</b> Cooling 49 db(A) Heating 49 db(A)	
<b>Power Supply</b> Normal Operational Voltage 208/230 V, 1 Phase, 60 Hz Voltage Range 187 - 253V Main Power Wire Size 14-2 AWG Interconnecting Cable Wire Size 14-4 AWG MCA 10 A MOCP/Breaker Size 15 A		<b>Dimensions &amp; Weights</b> Unit Dimensions (LxHxD) 35.4 x 23.5 x 14.9 -in Weight (Net/Shipping) 87/92 LBS	
		<b>Refrigerant Piping Data</b> Gas Pipe Size (OD) 1/2-in Liquid Pipe Size (OD) 1/4-in Connection Method Flared MAX Refrigerant Pipe Length 66-ft MIN Refrigerant Pipe Length 10-ft MAX Refrigerant Pipe Height Difference 50-ft	
			
			
			

## DIMENSIONAL SPECIFICATIONS

## TW12HTA3D

### INDOOR UNIT DIMENSIONS

Units: inch (mm)

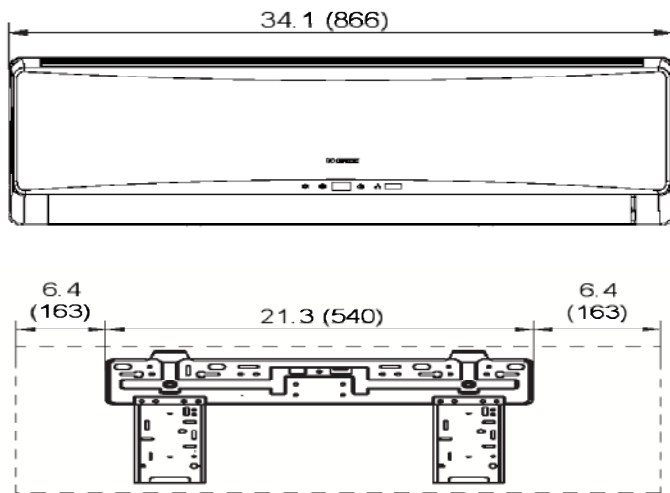

Liquid Line Valve	1/4-in OD Flared
Gas Line Valve	1/2-in OD Flared
Drain Connector	5/8-in OD

### OUTDOOR UNIT DIMENSIONS

Units: inch (mm)

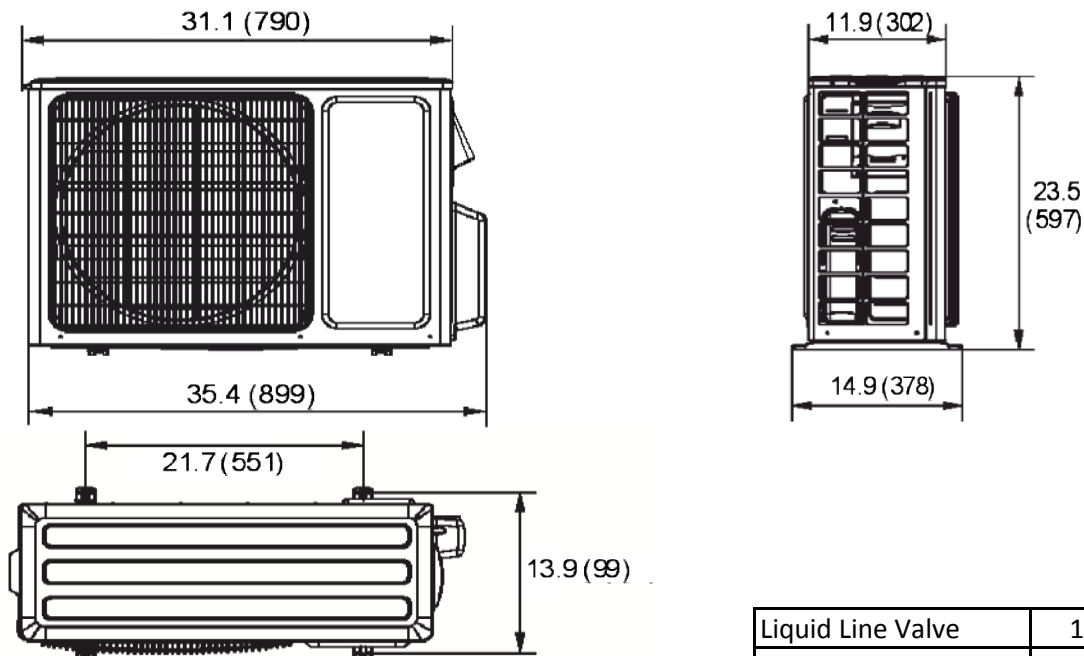

Liquid Line Valve	1/4-in OD Flared
Gas Line Valve	1/2-in OD Flared

### MINIMUM SPACING REQUIREMENTS

Units: inch (mm)

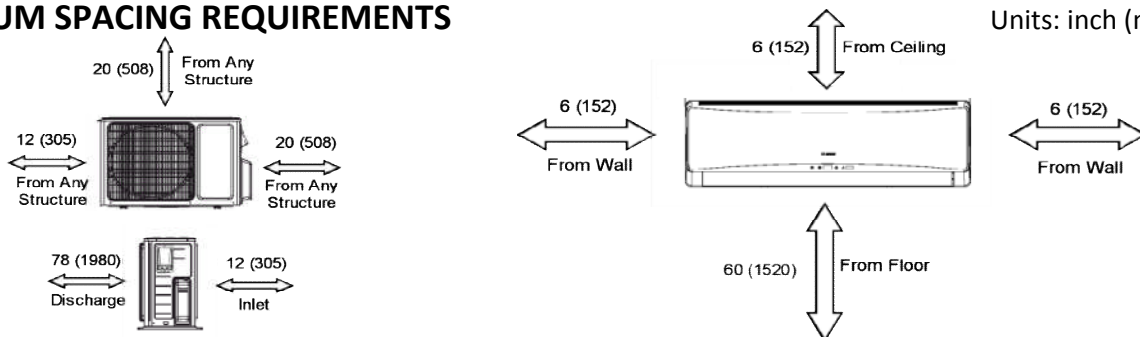

**Notes:**

1. Recommended Interconnecting Cable Type Stranded Bare Copper Conductors THHN 600V Wire
2. Power wiring cable size must comply with applicable national and local codes.
3. Test conditions are based on AHRI 210/240.

Specifications are subject to change without notice. Manufacturer reserves the right to discontinue or modify specifications or designs without notice or without incurring obligations. All rights reserved.